

(12) INTERNATIONAL APPLICATION PUBLISHED UNDER THE PATENT COOPERATION TREATY (PCT)

(19) World Intellectual Property Organization
International Bureau



(43) International Publication Date
4 January 2001 (04.01.2001)

PCT

(10) International Publication Number
WO 01/00307 A2

(51) International Patent Classification⁷: B01D 65/02, 65/08

(21) International Application Number: PCT/GB00/02295

(22) International Filing Date: 23 June 2000 (23.06.2000)

(25) Filing Language: English

(26) Publication Language: English

(30) Priority Data:
9914854.6 25 June 1999 (25.06.1999) GB

(71) Applicant (for all designated States except US): MILLENNIUMPORE LIMITED [GB/GB]; Unit 22, North East of England Business and Innovation Centre, Wearfield, Sunderland Enterprise Park East, Sunderland SR5 2TA (GB).

(72) Inventors; and

(75) Inventors/Applicants (for US only): PURDY, Martin [GB/GB]; 42 Morris Avenue, South Shields, Tyne &

Wear, NE34 9SZ (GB). WILKES, Ian, Peter [GB/GB]; 144 Reynolds Avenue, South Shields, Tyne & Wear, NE34 8JP (GB). WILKES, John, Steven [GB/GB]; 144 Reynolds Avenue, South Shields, Tyne & Wear; NE34 8JP (GB). WILKES, Kenneth, Ivan [GB/GB]; 144 Reynolds Avenue, South Shields, Tyne & Wear, NE34 8JP (GB). WILKES, Kristopher, Andrew [GB/GB]; 63 Bamburgh Avenue, South Shields, Tyne & Wear, NE34 7SZ (GB).

(74) Agent: COHEN, Alan, Nicol; 2 Grove Place, Tatsfield, Nr Westerham, Kent TN16 2BB (GB).

(81) Designated States (national): AE, AL, AM, AT, AU, AZ, BA, BB, BG, BR, BY, CA, CH, CN, CU, CZ, DE, DK, EE, ES, FI, GB, GD, GE, GH, GM, HR, HU, ID, IL, IN, IS, JP, KE, KG, KP, KR, KZ, LC, LK, LR, LS, LT, LU, LV, MD, MG, MK, MN, MW, MX, NO, NZ, PL, PT, RO, RU, SD, SE, SG, SI, SK, SL, TJ, TM, TR, TT, UA, UG, US, UZ, VN, YU, ZA, ZW.

(84) Designated States (regional): ARIPO patent (GH, GM, KE, LS, MW, MZ, SD, SL, SZ, TZ, UG, ZW), Eurasian patent (AM, AZ, BY, KG, KZ, MD, RU, TJ, TM), European patent (AT, BE, CH, CY, DE, DK, ES, FI, FR, GB, GR, IE,

[Continued on next page]

(54) Title: SELF CLEANING FILTER

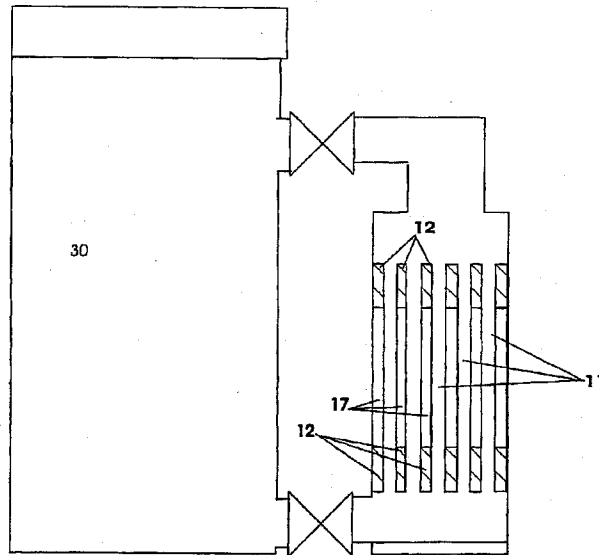

(57) Abstract: A self cleaning filter which works in dead end mode consists of a plurality of membrane module placed in a tank of waste water with an air diffuser to bubble air up over the surface of the membrane, the filtered water permeates through the membranes and is led away and the air keeps the membrane surface clear.

WO 01/00307 A2





IT, LU, MC, NL, PT, SE), OAPI patent (BF, BJ, CF, CG, CI, CM, GA, GN, GW, ML, MR, NE, SN, TD, TG).

For two-letter codes and other abbreviations, refer to the "Guidance Notes on Codes and Abbreviations" appearing at the beginning of each regular issue of the PCT Gazette.

Published:

— *Without international search report and to be republished upon receipt of that report.*

Self Cleaning Filter.

The present invention relates to a membrane based filtration device which is self cleaning and used under conditions of submersion in a contaminated feed stream.

5

Membrane based filtration devices are well known and are commonly used for solid/liquid separations.

10

The membrane is configured into a device where the liquid from a contaminated feed stream passes through the membrane and solids are rejected at the membrane surface, principally by size exclusion. The space into which this liquid flows is separated by a seal from the contaminated feed and is thereby treated, the treated liquid is contained within a filter housing which is fitted with an off take port such that the treated liquid may be extracted.

15

In all cases the productivity of the membrane filter is affected by the accumulation of solids that will occur at the membrane surface which results a deterioration in flow through the membrane, this phenomenon being known as concentration polarisation

20

A membrane system may be used in either dead end or cross flow modes of operation; in dead end operation liquid flow is exclusively through the membrane and is perpendicular to the membrane surface, resulting in a rapid build up of solids at the surface and consequential loss in productivity, in cross flow a liquid flow is induced tangentially to the membrane surface which has the effect of disrupting the accumulating solids and reducing the build up deposits which reduce the flow through the membrane.

25

US Patent 3807565 discloses an aerobic sewage disposal system in which air flow is used to break up solids as well as to oxidise them.

30

Patent Application WO 9411094 discloses a cross flow filtration arrangement in which there is an array of filter fibres in which gas bubbles flow over the fibres.

5 EP 0510328 discloses an activated sludge apparatus in which a plurality of membrane modules are arranged for the treatment of wastewater in which air is diffused at a lower level than the filter membrane modules serving to create upward agitation currents of both gas and liquid phases which are used to clean the outer surfaces membrane by the action of this upward cross flow. The system operates in crossflow not dead end mode.

10

However problems occur in crossflow filtration systems as, in use, blockages in the feed channels occur because of the presence of large particles and fibres which can enter the module channel under the action of the recirculatory currents which are necessarily set up. It is necessary to prescreen or strain the waste water to eliminate this tendency. For such processes a prescreen standard is typically set at a factor of 15 three times smaller than that of the membrane channel size.

We have now devised a self cleaning membrane based device which is used under conditions of submersion and in dead end operation.

20

According to the invention there is provided a filtration apparatus which comprises (i) a treating tank adapted to contain the water to be treated, (ii) a plurality of spaced apart filter membrane modules arranged vertically, (iii) an air inlet port positioned below the said filter membrane modules (iv) means to blow air through the inlet port and over the surfaces of the membranes and (v) water removal means to remove 25 treated water which has passed from the treating tank through the membranes the filter membranes being arranged in a housing and sealed at their ends, so that water permeates through the membrane modules to the water removal means.

30

In one embodiment the membrane modules are mounted within a housing which is placed within the tank and sealed from the liquid in the tank and the membrane modules are in the form of fibres or tubes so that only liquid passing through the membranes can pass into the housing and in use the water passes from inside the
5 fibres into the housing. In this embodiment the water passes from the tank to the inside of the fibres, through the membranes and the filtered water then passes into the housing from where the purified water is led away. The air is blown up over the inside of the membrane tubes or fibres and the air and the liquid turbulence caused removes any particles on the membranes which are then swept away in the stream.

10

The membrane modules can be in the form of hollow fibres or tubes sealed at both ends which are immersed in the liquid to be filtered. Preferably at the lower end of the fibres or tubes there is a means to restrict or prevent flow of water into the fibres or tubes whilst allowing the air to pass through. This can be achieved by having a
15 narrow gap around a seal at the lower end of the tube or fibre through which gap the air can pass, but water flow is restricted or alternatively the tube is sealed and there air injectors inside the tube through which air is injected into the inside of the tube.

20

The membrane modules are preferably in the form of tubes or fibres but can be in the form of flat sheets and, for a flat sheet membrane, the membrane module would comprise a membrane sealed on one or either side of a support plate with permeate off take channels formed by grooves or mesh and the flow would be through the membrane to the off take channels. The membrane can be in the form of flat membranes joined together to have e.g. a square or rectangular cross sectional shape.

25

In another embodiment of the invention the water permeates from the exterior of the membrane module through the membrane to a space from where the filtered water can be removed. The interior of the membranes are connected to a manifold and the air passes over the exterior of the membrane surfaces and the liquid turbulence
30 caused removes any particles on the membranes which are then swept away in the

stream. In this configuration there is a means to restrict or prevent flow of water around the membranes whilst allowing air to pass over the membranes.

5 The apparatus operates in the dead end mode unlike previous systems which hitherto have operated in cross flow mode.

10 In one embodiment the housing containing the membrane modules is submerged in the tank so the membranes are below the water surface, the static head of water provides a pressure which is sufficient to induce flow of water through the membrane even though this is of very low pressure. In another embodiment the membrane modules are positioned outside a tank holding the water with the modules at a lower level than the water in the tank so there a static head of water acting on the membrane modules.

15 The upward gas flow scours the membrane surface within the housing.

20 There is no stream of the water over or across the membrane so that there is a greatly reduced chance of large particles being trapped within the fibres and the egress of air at the top of the membrane modules will tend to prevent any penetration of large particles into the channels in or between the fibres from above the membrane modules.

25 The apparatus performs a membrane separation and there is no recirculatory flow induced and therefore the membrane modules do not suffer from the ingress of large solids into the channels where the contaminated feed-stream enters the module channel. In use large and heavy particles in the waste water settle out to the bottom of the tank and there is no water flow over the membrane surface which can pick up the particles and cause the channels to block.

5 The entire membrane surface of each membrane module can be uniformly and positively cleaned by agitation currents created by the air as it passes over the membranes as well as by the air itself. Therefore, even when large particulates are present in the treatment tank, they do not enter the top of the channels in the membrane modules because of the continuous egress of air from that channel and they cannot enter with the air because there is restricted or no access for water to flow in with the air. When there is a restricted passage for water to pass into the membrane module this restriction will act as a filter for large particles.

10 The membranes can be in the form of hollow fibres and the diameter of the hollow fibres can be up to 30 millimetres in diameter or higher, the higher diameter hollow fibres e.g. from 5 to 20 millimetres diameter for example from 10 to 20 millimetres diameter are especially suitable. The membrane can be made of any filtration plastic composition which is used for filtration, such as a polyethersulphone. The pore size
15 of the membrane can be in the ultrafiltration and microfiltration range. Suitable hollow fibre membranes are made by Milleniumpore Ltd. of Sunderland Enterprise Park, Sunderland SR5 2TA UK.

20 Preferably the air bubble fills the fibre, tube or lumen so that as it passes up there is efficient scouring of the membrane. If the tube is too small a diameter the air bubbles can get stuck by capillary or surface effects so the larger diameter tubes are preferred.

In use as the air bubbles pass up the fibre, tube or lumen and they displace water and scour the inner surface of the lumen; when the air bubbles reach the top of the lumen
25 they leave and water then flows back into the space left by the air bubble. The membrane can then be in substantial equilibrium with no cross flow of water but with the passage of water through the membrane and the surface of the membrane being scoured. This enables there to be long runs without blocking. In one embodiment the lumen can be backflushed to clear of any particles not removed.

30

The air can be passed over the tubes from a diffuser which generates air bubbles over an area sufficient so that air flows substantially uniformly over all the tubes. When there are a plurality of tubes particularly when there are larger numbers of tubes in a module e.g. more than five, it can be difficult for there to be a uniform flow of air
5 over all the tubes and if needed there can be a plurality of diffusers or air injectors so that there is a more uniform flow of air and hence cleaning performance for all the tubes.

The number of tubular membranes will depend on the size of the unit and the
10 application in one type of unit the number can range from fifty to several hundred, but this is not critical.

It is surprising that a relatively small static head of water, with little or no water flow over the membrane, can be sufficient to cause filtered water to pass through the
15 membrane so that the membrane surface can be scoured by air with limited chance of particles which have been carried to the membrane by any water flow blocking the membrane.

The invention is described in the accompanying drawings in which: -

20

Figure 1 is a sectional view showing a first embodiment of the invention

Figure 2 is a sectional view showing a second embodiment of the invention

Figure 3 is a schematic view of one form of the apparatus

Figure 4 is a sectional view of a third embodiment of the invention and

25 Figure 5 shows schematically bubbles inside a tube

Referring to figure 1, in this embodiment the filtration occurs from the exterior of the membrane module through the membrane to a space which is the filtrate off take.

A treating tank (1) containing the water to be filtered has a housing (2) in which there is a filter unit which comprises a plurality of membrane filter modules (3) which are tubes of diameter 10 millimetres made of an ultrafiltration polysulphone membrane. The tubes are vertically arranged within the housing (2) and the interspatial space (9) between the modules at the top of the device is the channel for feed entry. There is an air diffuser (4) through which air can be fed from air inlet (8) to the exterior of filter elements in the modules (3) and through the passages (10) between the membranes. There is a manifold (11) connected to the interior of the membrane modules and a take off from (11).

10

In use the tank (1) is filled with the waste water to be purified to a level above the membrane modules. Purified water permeates through the membrane modules (3) and is led off. The air diffuser (4) is activated and air bubbles bubble up through the spaces (10) between the membranes and which provides the agitation for cleaning the membrane surface.

15

In this configuration for a tubular membrane module, the flow is from the outside of the module to the inner lumen channel (3) commonly manifolded from each module.

Referring to figure 2 in this embodiment of the invention the filtration occurs from the interior of the membrane module through the membrane to void space within the housing which is the filtrate off take channel.

The filter unit comprises a plurality of membrane filter modules (11) of the same type as in fig. 1 positioned within the treating tank (1) and which are vertically arranged within the casing (2), an encapsulating seal (12) is effected between the feed and filtrate channels. Air is delivered at a diffuser (4) through air inlet (15) which provides the agitation for cleaning the membrane surface. The interior of the tubular membrane lumens are the channels for feed entry of the waste water and there is take off (16) which is the permeate outlet connection permeate.

30

In use the tank (1) is filled with the waste water to be purified to a level above the membrane modules. The water permeates through the membrane from the inside of the modules (11) to the spaces between the membranes (17) where it is led away through outlet (16). For a flat sheet membrane the module would comprise of two membrane sheets sealed either side of a support frame. The air from the diffuser (4) passes through the interior of the membranes (11) and cleans the membrane surface.

Referring to fig. 3 a treatment tank (20) contains the waste water to be treated, housing (21) contains 10 millimetre diameter hollow polysulphone tubes (22) of the same type as in fig. 1 and the space between their ends are sealed. There is an air inlet (23) connected to bubble diffuser (24). The interior of tubes (22) are open to the water in the tank and there is a water outlet (25) connected to the housing.

In use the tank (20) is filled to a level above the membranes and the water permeates from the inside of the tubes (22) through the membrane to the void space in housing (21). Air is fed through inlet (23) to diffuser (24) where the air bubbles up through membrane channels.

Referring to fig. 4, this shows a membrane module as in fig. 2 but outside tank (30) containing the water to be filtered. The water from the tank is connected to the housing (31) containing the tubes through connections (32) and (33).

Referring to fig. 5, which shows an air bubble (35) passing up membrane tube (36) in a stream of water, as the air and water passes over the tube surface and filtered water passes through the tube (36) in conventional cross flow mode, particles drawn to the membrane channel with the liquid can accumulate or bridge together and block the membrane channel. In fig. 5b, which shows an embodiment of the invention, there is restricted flow of water into the bottom of the tube (37) so the water recirculates as shown by the arrows, the water entering at the top of the tube. The air bubbles then

can keep the tube surface clear and there is less chance of particles being brought into contact with the tube surface by the flow of water. Referring to fig. 5c, when the bubble (38) is a close fit in the tube (39) there is a region of relatively high velocity of liquid at (40) around the side of the bubble (38) and over the surface of the tube, when the bubble reaches the top of the tube any large particles will tend to be lifted out of the tube by the bubble as it leaves the tube.

Claims

1. A filtration apparatus which comprises (i) a treating tank adapted to contain the water to be treated, (ii) a plurality of spaced apart filter membrane modules arranged vertically, (iii) an air inlet port positioned below the membrane modules (iv) means to blow air through the inlet port and over the surfaces of the membranes and (v) water removal means to remove treated water which has passed from the treating tank through the membranes, the filter membranes being arranged in a housing and sealed at their ends, so that water permeates through the membrane modules to the water removal means.
2. A filtration apparatus as claimed in claim 1 in which the membrane modules are positioned within the tank.
3. A filtration apparatus as claimed in claim 1 in which the membrane modules are positioned outside the tank.
4. A filtration apparatus as claimed in any one of claims 1 to 4 in which the membrane modules are mounted within a housing, which housing is sealed from the liquid in the tank so that only liquid passing through the membranes can pass into the housing.
5. A filtration apparatus as claimed in any one of claims 1 to 4 in which the membranes are in the form of tubes or fibres and in use the water passes from inside the tubes or fibres into the housing.
6. A filtration apparatus as claimed in claim 5 in which there is a means to restrict access of water to the lower end of the tubes or fibres.

7. A filtration apparatus as claimed in claim 6 in which the lower ends of the tubes or fibres are sealed and the air is injected to the inside of the tubes or fibres.
8. A filtration apparatus as claimed in any one of claims 1 to 4 in which the
5 membranes are in the form of tubes or fibres and the interior of the tubes or fibres are connected to a manifold and, in use, the water passes from outside the fibres into the manifold, the water removal means being connected to the manifold.
9. A filtration apparatus as claimed in claim 8 in which there is a means to restrict
10 access of water to the space adjacent the outside of the lower end of the tubes or fibres.
10. A filtration apparatus as claimed in claim 8 in which the space between the lower ends of the tubes or fibres is sealed and air is injected into this space.
- 15 11. A filtration apparatus as claimed in any one of claims 5 to 10 in which the fibres have a diameter of from 5 to 30 millimetres.
12. A filtration apparatus as claimed in any one of the preceding claims in which the
20 membrane modules comprise flat sheet membranes which are sealed on one or either side of a support plate with permeate off take channels are formed by grooves or mesh in the support plate.
13. A filtration apparatus as claimed in any one of the preceding claims in which the
25 membranes are made of a polyether sulphone.

1/5

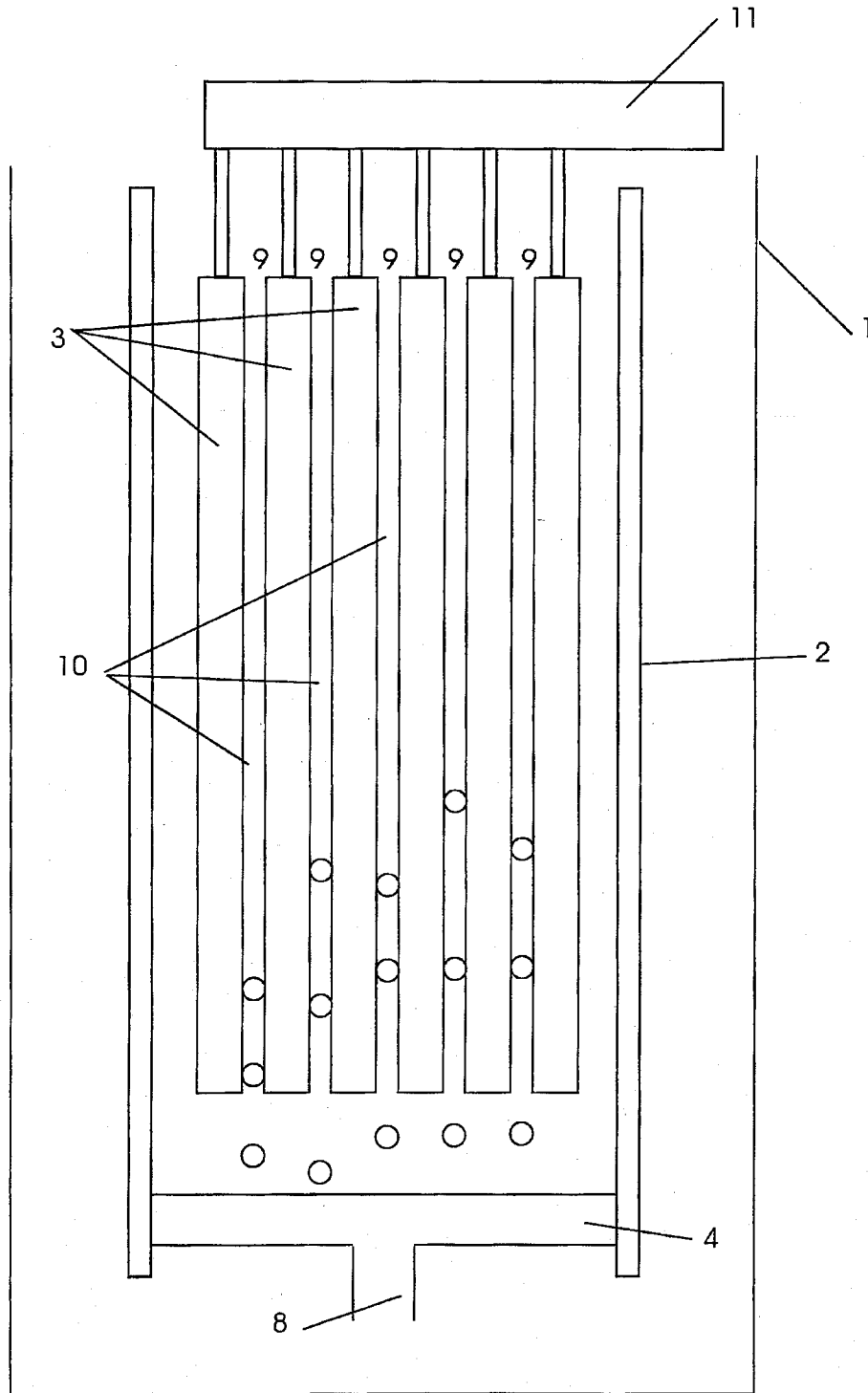

Fig. 1

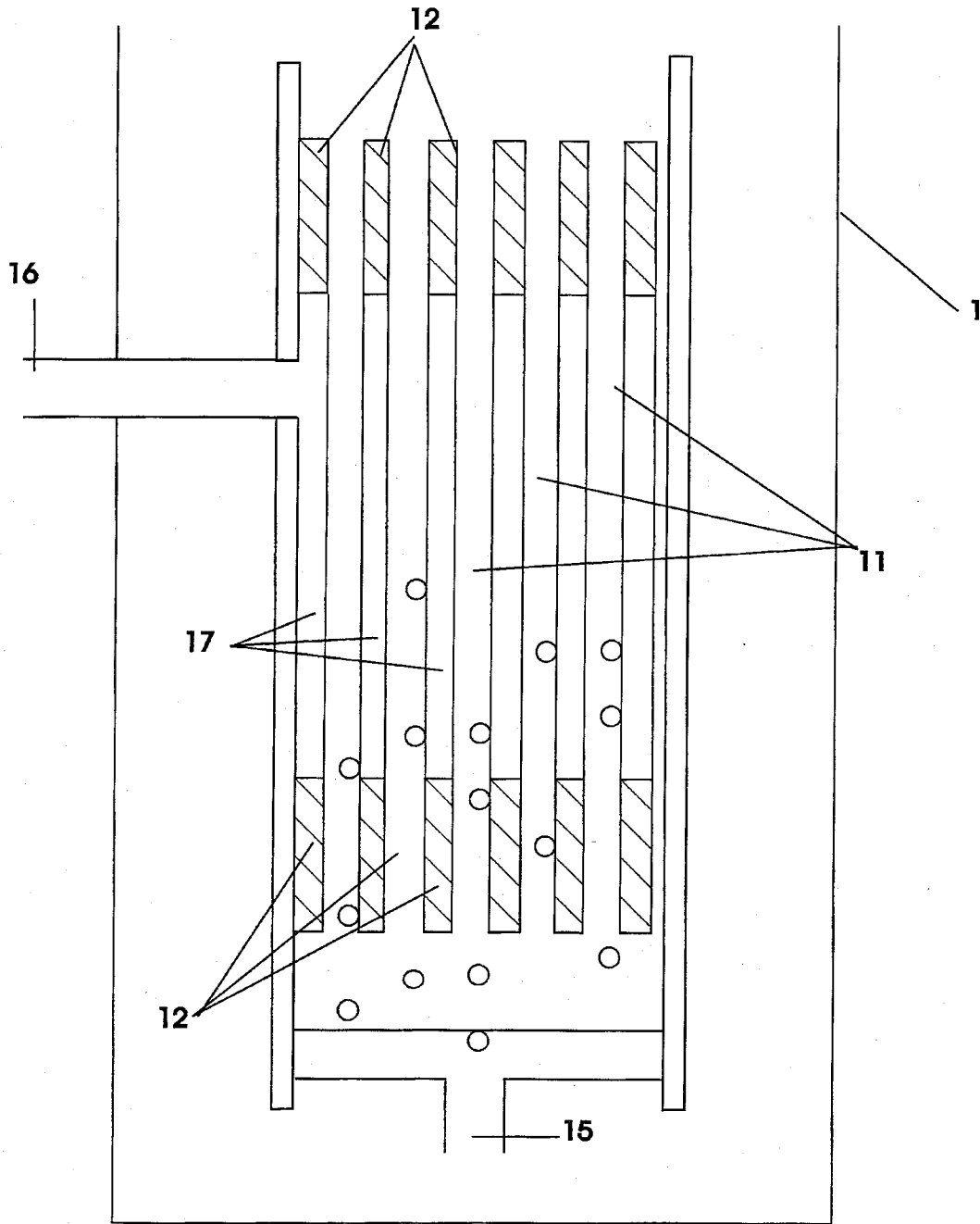

Fig. 2

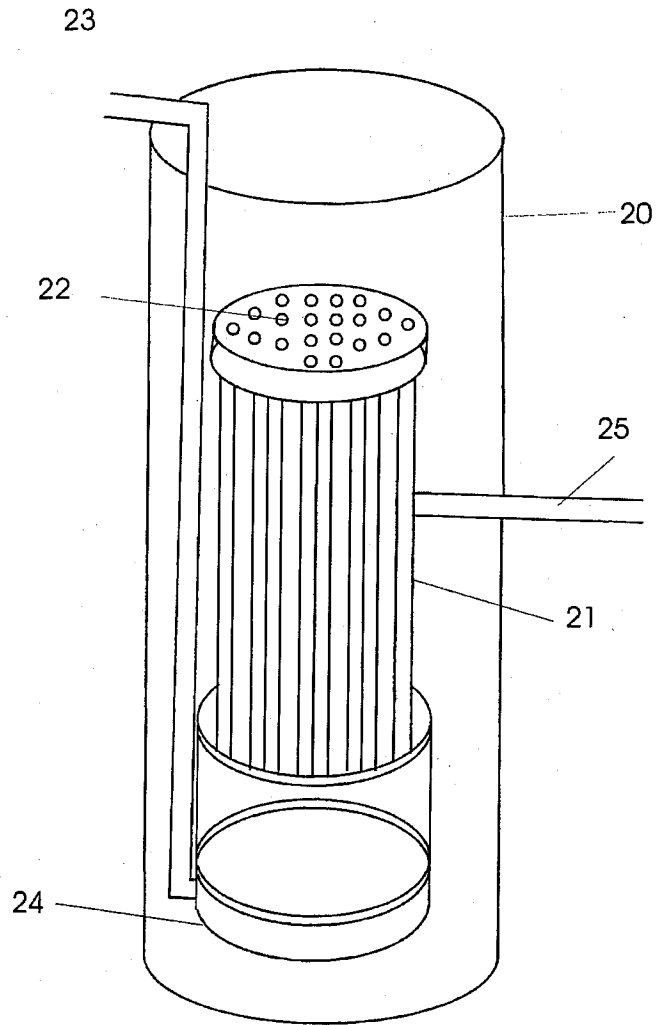

Fig. 3

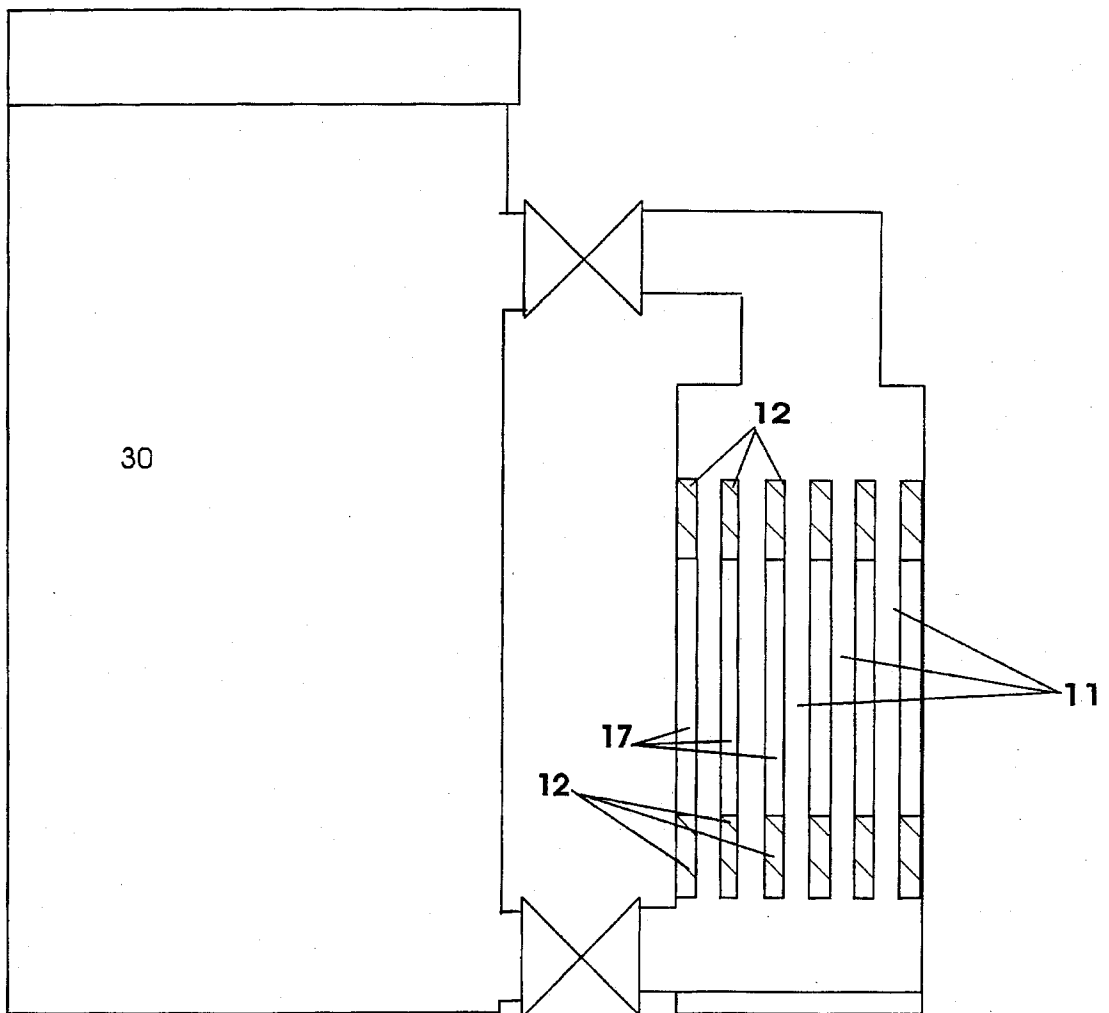

Fig. 4

5/5

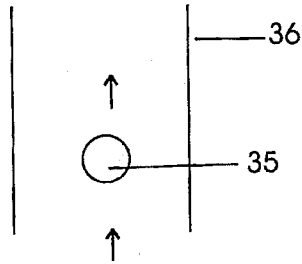

Fig. 5a

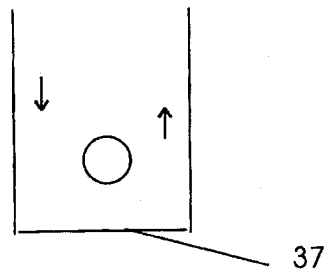

Fig. 5b

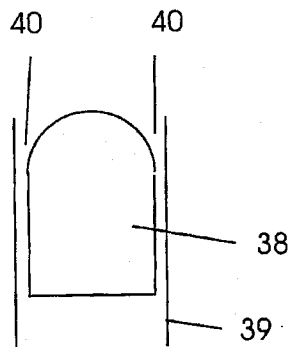

Fig. 5c